

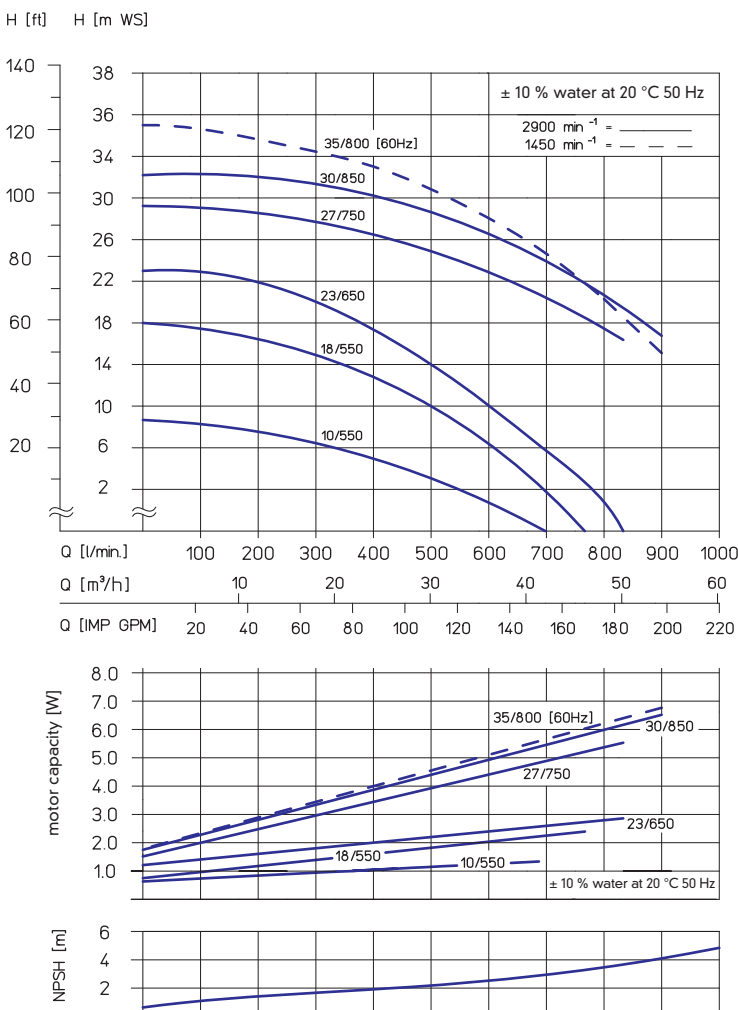

- Delivery rate up to 900 l/min
- Delivery head up to 35 m wc
- No shaft seal required
- For aggressive and neutral liquids
- Made of PP or PVDF
- Protection class IP 55

Magnetically coupled centrifugal pumps of type 4.5 are non-self-priming pumps that operate in horizontal position and are made in monobloc design. A magnetic coupling connects the pump to the motor and transmits the power of the motor to the impeller.

PERFORMANCE CHARTS



STANDARD DESIGN

Housing, impeller and impeller magnet coating are made of glass-fibre reinforced PP plastic or PVDF. Sleeve bearings, starting rings and centering shaft are made of 99.7 % pure oxide ceramic, and the O-ring sealing of the housing is made of either FKM or EPDM. (See table on page 7 for other materials.)



NON-SELF-PRIMING RM – TYPE 4.5

TECHNICAL DATA

size	10/550	18/550		23/650	27/750	30/850	35/800*
maximum delivery rate [l/min]	700	750		833	833	900	900
maximum delivery head [m wc]	9.0	18.0		23,0	28,0	32	35
maximum density [g/cm ³] ^{***}	1.6	1.25	1.7	1.4	1.0	1.15	1.0
motor capacity at 50 Hz [kW]	2.2	3.0	4.0	4.0	5.5	7.5	–
motor capacity at 60 Hz [kW]	2.6	3.6	4.8	4.8	6.6	9.0	6.6
current rating (400 V) [A]	4.9	6.25	8.1	8.1	11.0	14.5	13.8
rated speed at 50 Hz [min ⁻¹]	1450	2900		2900	2900	2900	–
rated speed at 60 Hz [min ⁻¹]	1750	3440		3440	3440	3440	3440
weight [kg]	28.0	34.0	36.0	37.0	47.0	57.0	48.5

voltage**	230 V ac or 230/400 V three-phase current		
protection class	hose-proof according to IP 55		
ports	suction side G 2 3/4		discharge side G 2 1/4
recommended maximum flow rate	suction side 1 m/s		discharge side 3 m/s
material	PP		PVDF
maximum temperature	80 °C		95 °C
maximum system pressure at 20 °C	5.0 bar		6.0 bar

* Available only in 60 Hz.

** Other voltages available upon request.

*** With maximum volume rate of flow. To deliver liquids with a higher relative density, the pump has to be throttled (see the following performance chart).

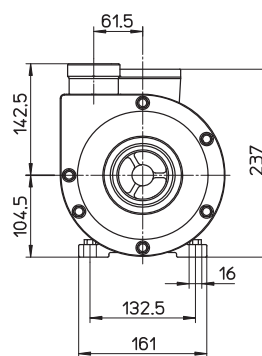
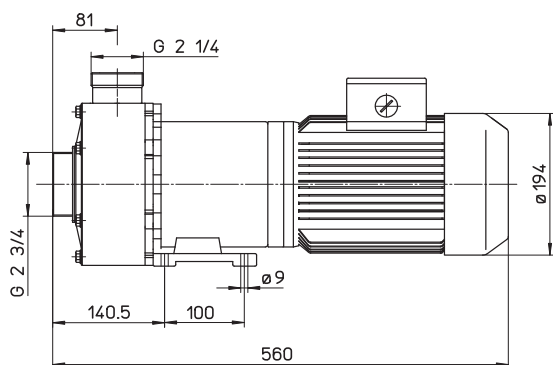

dimensions for standard motor up to 4.0 kW

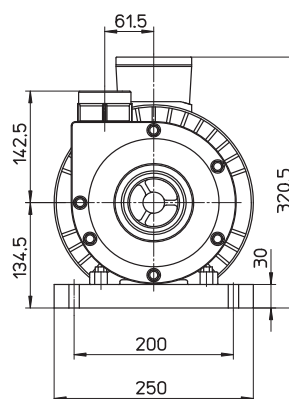
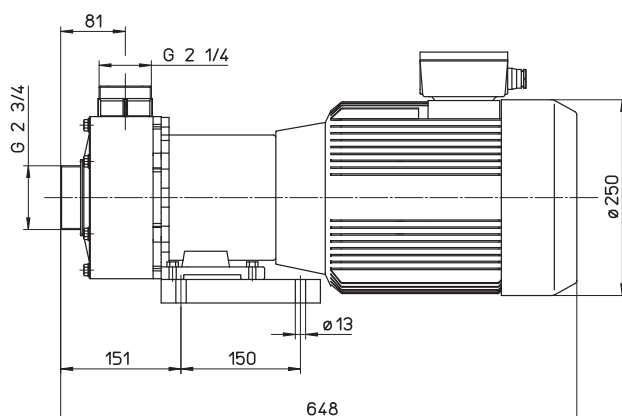

dimensions for standard motor up to 7.5 kW

Position of the terminal box: standard position is on top (if you need it mounted on the right or the left, please indicate when placing your order).
Position of the discharge port: vertical position is standard (differing positions at 12 x 30° are possible, please indicate when placing your order).